

600mA, High Efficiency uPOL Module

MUN3C1HR6-FB

FEATURES:

- High Density uPOL Module
- 600mA Output Current
- Input Voltage Range from 2.3V to 5.0V
- 1.82V Fixed Output Voltage
- 6MHz Fixed-Frequency at Force PWM
- Low Ripple Light-Load PFM Mode
- Automatic PFM/PWM Mode Switching
- Input Under-Voltage Lockout(UVLO)
- Internal Soft-Start
- Thermal Shutdown and Overload Protection
- Compact Size: 2.5mm*2.3mm*1.05mm
- Pb-free for RoHS compliant
- MSL 2, 260°C Reflow

APPLICATIONS:

- Point of Load Conversion
- Portable devices / wearable devices
- 3G, 4G WiFi, WIMAX, and WiBro Data card
- Tablets
- DSC, DVC

GENERAL DESCRIPTION:

The uPOL module is a non-isolated dc-dc converter that can deliver up to 600mA of output current. The PWM switching regulator, high frequency power inductor, input and output capacitors are integrated in one hybrid package. No additional components are required to finish the design.

The module has automatic operation with PWM mode and power saving mode according to loading. Other features include remote enable function, internal soft-start, over current protection, and input under voltage locked-out capability.

The low profile and compact size package (2.5mm × 2.3mm × 1.05mm) is suitable for automated assembly by standard surface mount equipment. The uPOL module is Pb-free and RoHS compliance.

TYPICAL APPLICATION CIRCUIT & PACKAGE:

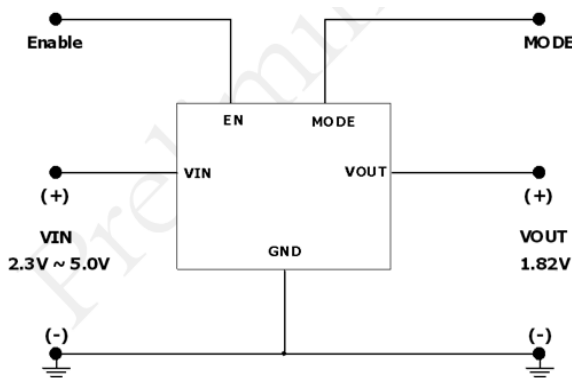

FIG.1 TYPICAL APPLICATION CIRCUIT

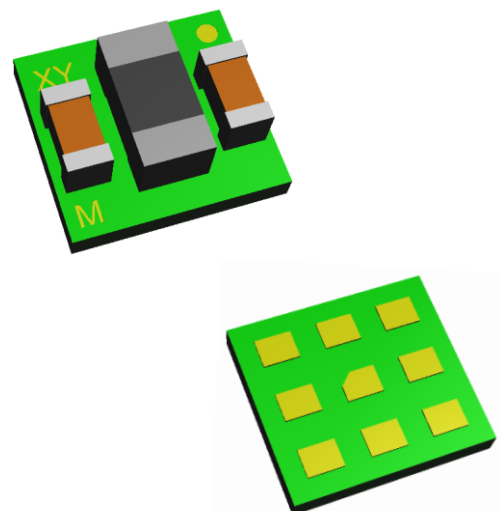

FIG.2 HIGH DENSITY LOW PROFILE uPOL MODULE

ELECTRICAL SPECIFICATIONS:

CAUTION: Do not operate at or near absolute maximum rating listed for an extended period of time. This stress may adversely impact product reliability and result in failures outside of warranty.

Parameter	Description	Min.	Typ.	Max.	Unit
■ Absolute Maximum Ratings					
VIN to GND		-0.3	-	+7.0	V
MODE to GND		-0.3	-	VIN+0.3	V
EN to GND		-0.3	-	VIN+0.3	V
Tc	Case Temperature of Inductor	-	-	+110	°C
Tj	Junction Temperature	-40	-	+125	°C
Tstg	Storage Temperature	-40	-	+125	°C
ESD Rating	Human Body Model (HBM)	-	2.0K		V
	Machine Model (MM)	-	200		V
	Charge Device Model (CDM)	-	1.5K		V
■ Recommendation Operating Ratings					
VIN	Input Supply Voltage	+2.3	-	+5.0	V
VOUT	Fixed Output Voltage		+1.82		V
Ta	Ambient Temperature	-40	-	+85	°C
■ Efficiency					
EFF	@10mA		87		%
EFF	@600mA		87		%
■ Thermal Information					
Rth(jchoke-a)	Thermal resistance from junction to ambient. (Note 1)	-	TBD	-	°C/W

Note 1: Rth(jchoke-a) is measured with the component mounted on an effective thermal conductivity test board with 0 LFM condition. The test board size is 30mm×30mm×1.6mm with 4 layers. The test condition is complied with JEDEC EIJ/JESD 51 Standards.

ELECTRICAL SPECIFICATIONS: (Cont.)

 Conditions: $T_A = 25\text{ }^\circ\text{C}$, $V_{in}=3.8\text{V}$, $V_{out}=1.82\text{V}$, unless otherwise specified.

Symbol	Parameter	Conditions	Min.	Typ.	Max.	Unit
■ Input Characteristics						
$I_{SD(IN)}$	Input shutdown current	$V_{in} = 3.8\text{V}$ $EN = GND$		0.1	1	μA
$I_{Q(IN)}$	Input supply bias current	$V_{in} = 3.8\text{V}$, $I_{out} = 0\text{A}$ $V_{out} = 1.82\text{V}$ $EN = VIN$		25	50	μA
$I_{S(IN)}$	Input supply current	$V_{in} = 3.8\text{V}$, $EN = VIN$, $MODE = GND$				
		$I_{out} = 1\text{mA}$ $V_{out} = 1.82\text{V}$		0.54		mA
		$I_{out} = 10\text{mA}$ $V_{out} = 1.82\text{V}$		5.46		mA
		$I_{out} = 600\text{mA}$ $V_{out} = 1.82\text{V}$		0.33		A
■ Output Characteristics						
$I_{OUT(DC)}$	Output continuous current range	$V_{in} = 3.8\text{V}$, $V_{out} = 1.82\text{V}$	0		600	mA
V_O	Output voltage accuracy	$V_{out} = 1.82\text{V}$, $MODE = GND$	-3.5		+3.5	%
$V_{OUT(AC)}$	Output ripple voltage	$V_{in} = 3.8\text{V}$, $V_{out} = 1.82\text{V}$, $EN = VIN$, $BW = 10\text{MHz}$				
		$I_{OUT} = 50\text{mA}$		25		mVp-p
		$I_{OUT} = 600\text{mA}$		10		mVp-p
R_{DIS}	Output discharge resistance	$EN = GND$		230		Ω
T_{SS}	Soft-start	$V_{in} = 3.8\text{V}$, $V_{out} = 1.82\text{V}$		180		μs

ELECTRICAL SPECIFICATIONS: (Cont.)

 Conditions: $T_A = 25\text{ }^\circ\text{C}$, $V_{in}=3.8\text{V}$, $V_{out}=1.82\text{V}$ unless otherwise specified.

Symbol	Parameter	Conditions	Min.	Typ.	Max.	Unit
■ Control Characteristics						
V_{MODE}	VMODE_H	High, Force PWM mode	1.2			V
	VMODE_L	Low, Automatic PFM/PWM mode			0.4	V
V_{EN}	VEN_H	Enable High-Level Input Voltage	1.2			V
	VEN_L	Enable Low-Level Input Voltage			0.4	V
■ Fault Protection						
V_{UVLO_TH}	Under voltage lockout threshold	Rising V_{in}		2.15	2.27	V
T_{OTP}	Over temp protection			150		$^\circ\text{C}$
I_{LIMIT_TH}	Current limit threshold	Peak value of inductor current, (Note 2)	0.9	1.1	1.25	A

Note 2: Current limit spec is based on IC parameter.

ORDER INFORMATION:

Part Number	Ambient Temp. Range ($^\circ\text{C}$)	Package (Pb-Free)	MSL	Note
MUN3C1HR6-FB	-40 ~ +85	LGA	Level 2	-

Order Code	Packing	Quantity
MUN3C1HR6-FB	T/R	3,000

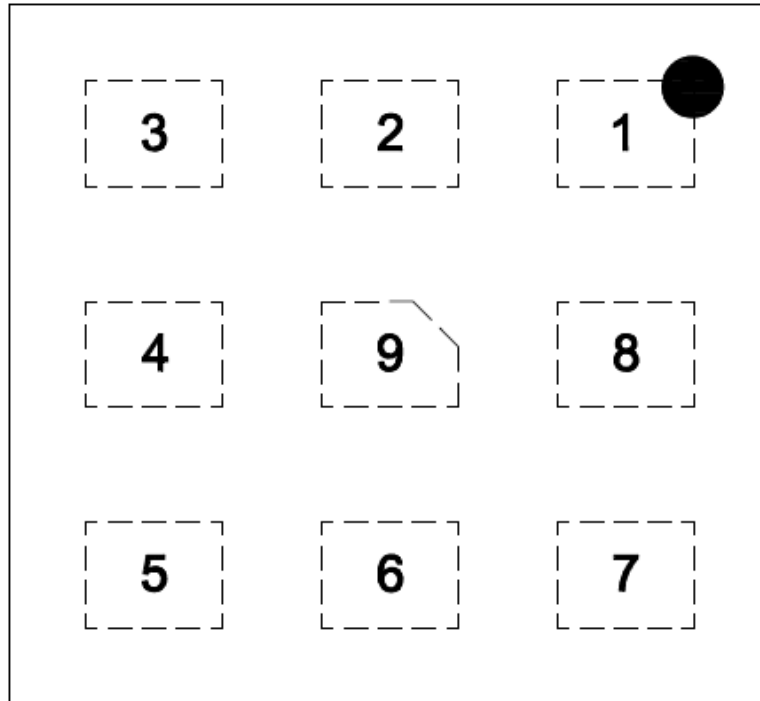
PIN CONFIGURATION:

TOP VIEW
PIN DESCRIPTION:

Symbol	Pin No.	Description
MODE	1	This is the mode selection pin. Mode=High: Low-noise mode enable, force the module to stay in PWM mode. Mode=Low: The module is operating in PFM at light load current, and in PWM at high load current. Do not leave this pin floating.
GND	2, 6, 9	Ground pin.
VOUT	3, 4	Power output pin. Connect to output for the load.
EN	5	This is the enable pin of the module. Connect this pin to GND keeps the module in shutdown mode. Pulling this pin to VIN enables the module with soft start. Do not leave this pin floating.
VIN	7, 8	Power input pin.

TYPICAL PERFORMANCE CHARACTERISTICS: (1.82VOUT)

Conditions: $T_A = 25\text{ }^\circ\text{C}$, unless otherwise specified. Test Board Information: 30mm×30mm×1.6mm, 4 layers. The output ripple and transient response are measured by short loop probing and limited to 10MHz bandwidth. The following figures are the typical characteristic curves at 1.82Vout.

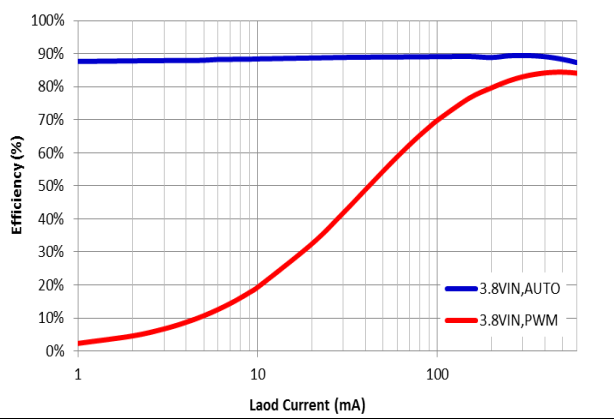

FIG.3 EFFICIENCY V.S. LOAD CURRENT

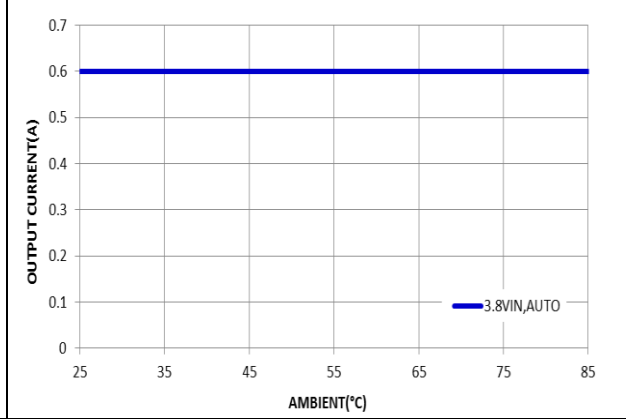

FIG.4 DE-RATING CURVE AT 3.8VIN

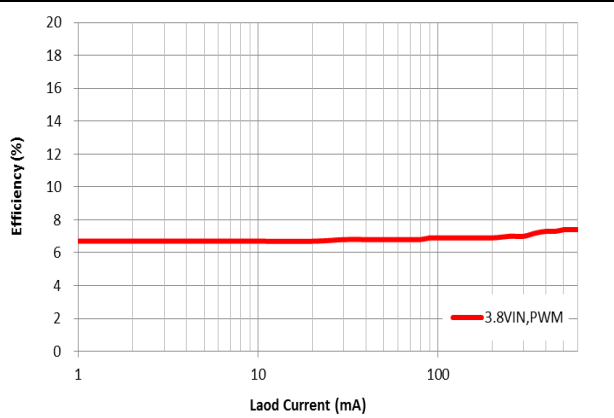

FIG.5 OUTPUT RIPPLE (3.8VIN, MODE=VIN)

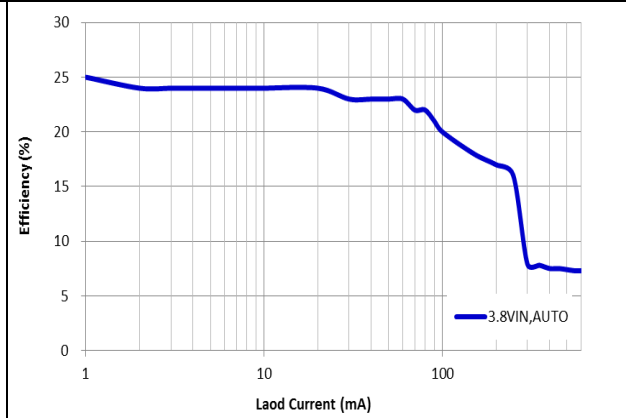

FIG.6 OUTPUT RIPPLE (3.8VIN, MODE=GND)

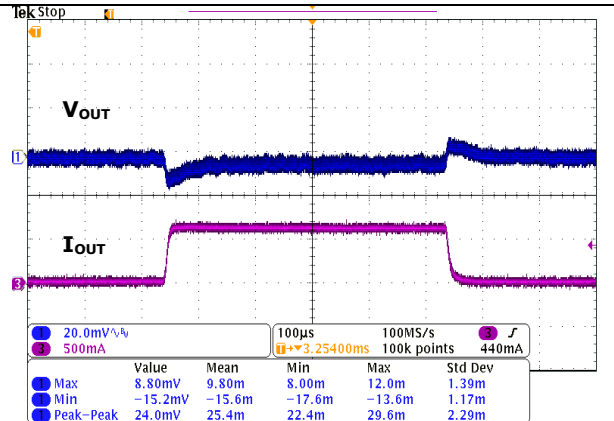

FIG.7 TRANSIENT RESPONSE (3.8VIN, 0% to 100% LOAD STEP, MODE=VIN)

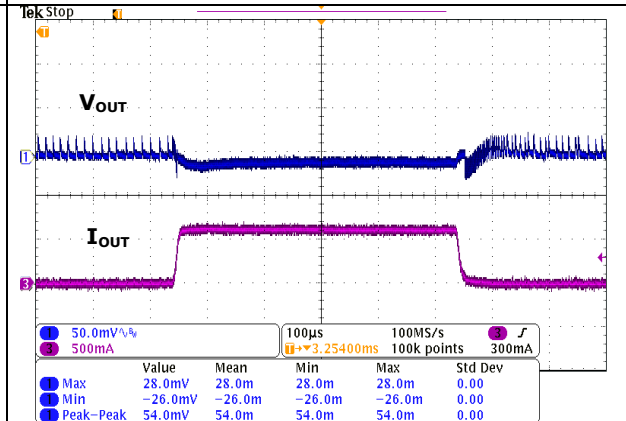

FIG.8 TRANSIENT RESPONSE (3.8VIN, 0% to 100% LOAD STEP, MODE=GND)

Detailed Description:**MODE Selection:**

The MODE pin allows one to select the operation mode. Logic high on this pin forces the module to stay in Force PWM mode. A Logic low allows the module to automatically switch to PFM during light load.

UVLO (Under voltage Lockout):

When EN is HIGH, the under voltage lockout keeps the module from operating until the input supply voltage rises high enough to properly operate. This ensures no misbehavior of the module during startup or shutdown.

Soft Start:

The device has an internal soft-start function that limits inrush current during start-up. The nominal soft-start is 180 μ S.

Enable:

When EN is LOW, all circuits are off and the IC draws $\sim 0.1\mu$ A of current. When EN is HIGH and Vin is above its UVLO threshold, the module begins a soft-start cycle. For proper operation, the EN pin must be terminated to logic high and not left floating.

Over Current Protection:

A heavy load or short circuit on the output causes the current in the inductor to increase until a maximum current threshold is reached in the high-side switch. Upon reaching this point, the high-side switch turns off, preventing high currents from causing damage. The regulator continues to limit the current cycle-by-cycle. After 16 cycles of current limit, the regulator triggers an over current fault, causing the regulator to shut down for about 1.3ms before attempting a restart.

Thermal Shutdown:

When the internal die temperature increases, due to a high load condition and/or a high ambient temperature; the output switching is disabled until the die temperature falls sufficiently. The junction temperature at which the thermal shutdown activates is nominally 150°C with a 15°C hysteresis.

APPLICATIONS INFORMATION:**REFERENCE CIRCUIT FOR GENERAL APPLICATION:**

The MUN3C1HR6-FB is a complete dc-dc power module requiring no additional external components. Figure 9 shows the module application schematic for input voltage at +3.8V.

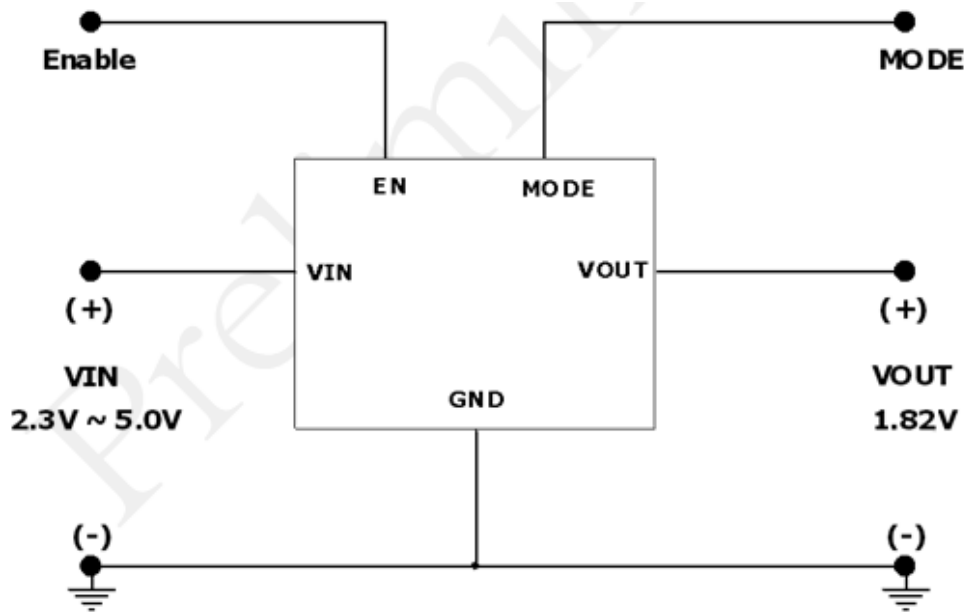
**FIG.9 REFERENCE CIRCUIT FOR GENERAL APPLICATION**

APPLICATIONS INFORMATION: (Cont.)**Thermal Considerations:**

All thermal testing conditions are complied with JEDEC EIJ/JESD 51 Standards. Therefore, the test board size is 30mm×30mm×1.6mm with 4 layers. The case temperature of module sensing point is shown as Figure 10. Then $R_{th(j_{choke}-a)}$ is measured with the component mounted on an effective thermal conductivity test board with 0 LFM condition. The MUN3C1HR6-FB module is designed for using when the case temperature is below 110°C regardless to any change of output current, input/output voltage or ambient temperature.

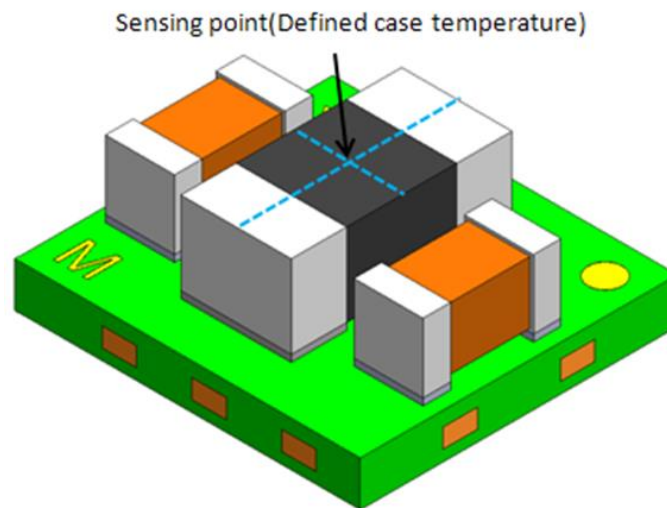
**FIG.10 Case Temperature Sensing Point**

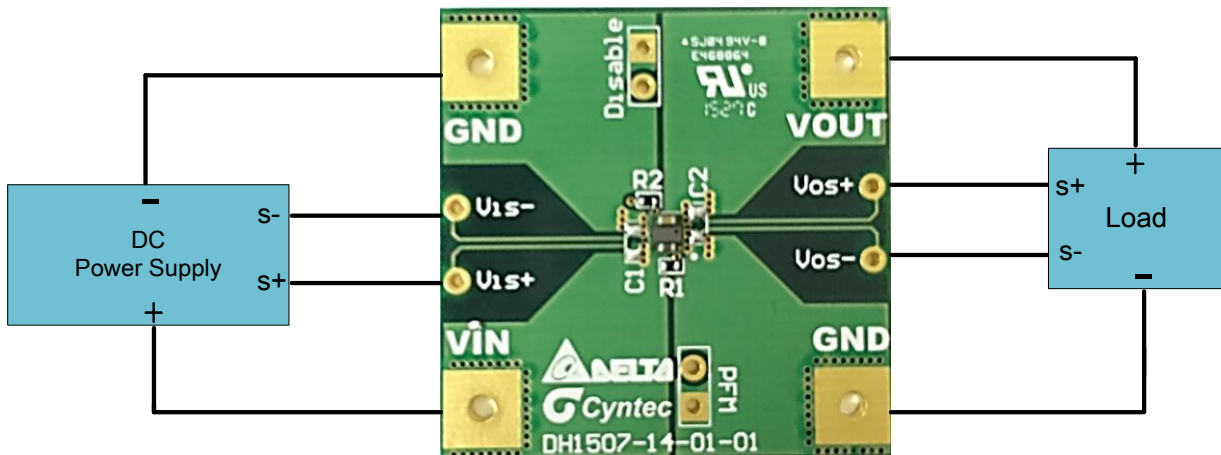
TEST CONFIGURATION:
Micro POL module evaluation board

The enable connector has two states (ON and OFF)

1. The R2 pull high resistor has been connected to VIN and EN already.
2. Connect a dc power supply between VIN and GND on the EVB to enable the module. Note that the input voltage should range from 2.3V to 5.0V. Keep the wires from the input power supply to EVB as short as possible.
3. Use a jumper connector to short the "Disable" pin to ground for shut down of the module.

The mode connector has two states (PWM, PFM/PWM)

1. The R1 pull high resistor has been connected to VIN and MODE for force PWM operation.
2. Use a jumper connector to short the "PFM" pin to ground for PFM/PWM operation.

REFLOW PARAMETERS:

Lead-free soldering process is a standard of electronic products production. Solder alloys like Sn/Ag, Sn/Ag/Cu and Sn/Ag/Bi are used extensively to replace the traditional Sn/Pb alloy. Sn/Ag/Cu alloy (SAC) is recommended for this power module process. In the SAC alloy series, SAC305 is a very popular solder alloy containing 3% Ag and 0.5% Cu and easy to obtain. Figure 11 shows an example of the reflow profile diagram. Typically, the profile has three stages. During the initial stage from room temperature to 150°C, the ramp rate of temperature should not be more than 3°C/sec. The soak zone then occurs from 150°C to 200°C and should last for 60 to 120 seconds. Finally, keep at over 217°C for 60 seconds limit to melt the solder and make the peak temperature at the range from 240°C to 250°C. It is noted that the time of peak temperature should depend on the mass of the PCB board. The reflow profile is usually supported by the solder vendor and one should adopt it for optimization according to various solder type and various manufacturers' formulae.

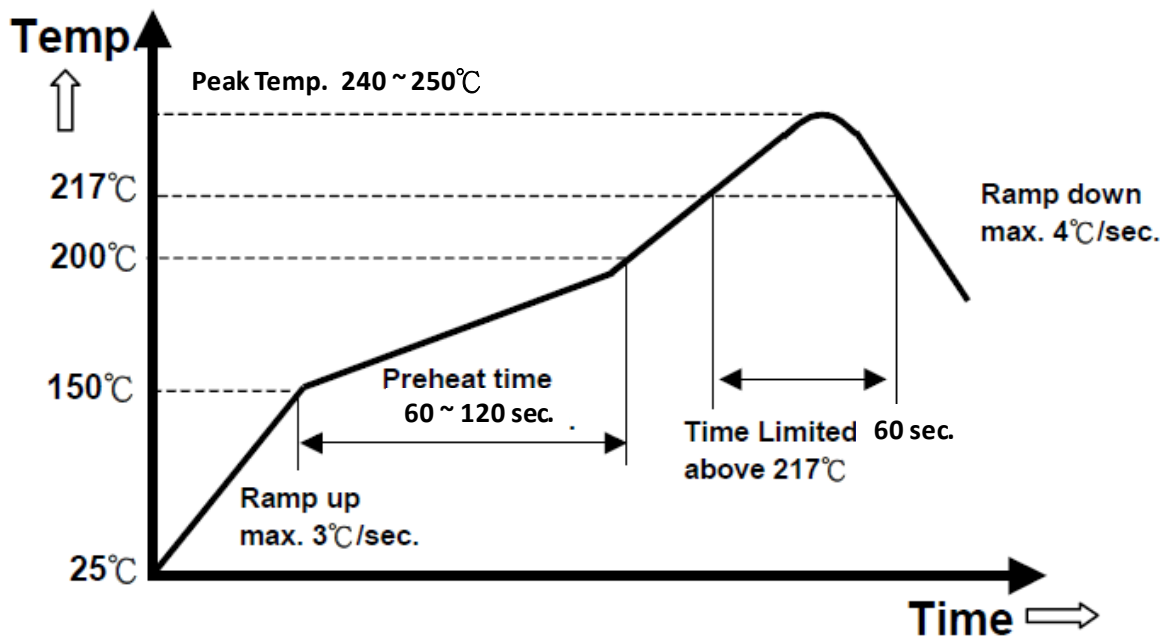
FIG.11 Recommendation Reflow Profile

PACKAGE OUTLINE DRAWING:

Unit: mm

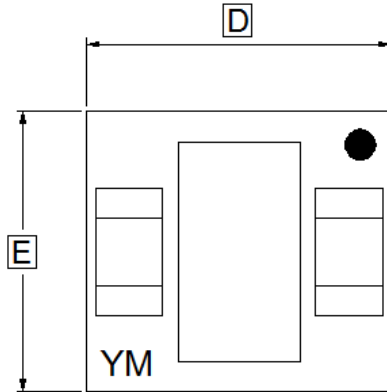
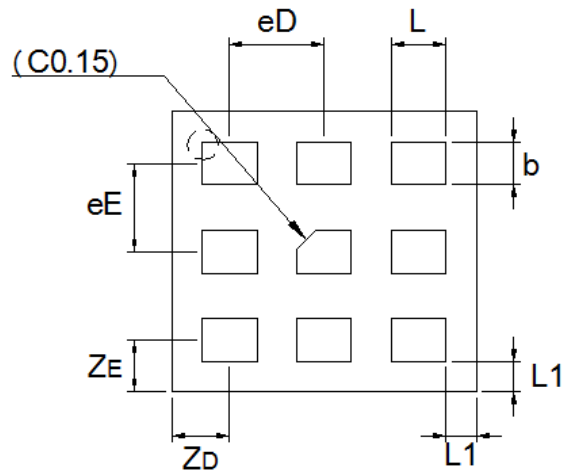
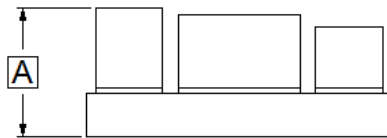
TOP VIEW

BOTTOM VIEW

END VIEW

DIM	MILIMETERS		
	MIN.	NOM.	MAX.
A			1.050
b	0.250	0.350	0.450
D	2.300	2.500	2.700
E	2.100	2.300	2.500
eD	0.675	0.775	0.875
eE	0.625	0.725	0.825
L	0.350	0.450	0.550
L1	0.050	0.250	0.450
Z _D	0.275	0.475	0.675
Z _E	0.225	0.425	0.625

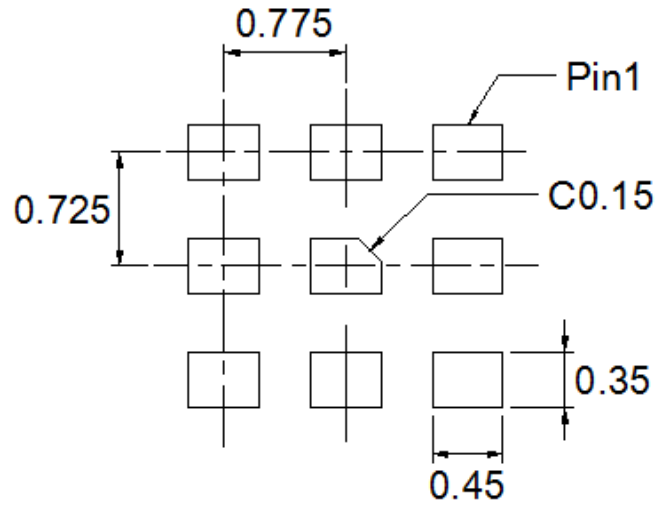
LAND PATTERN REFERENCE:

Unit: mm

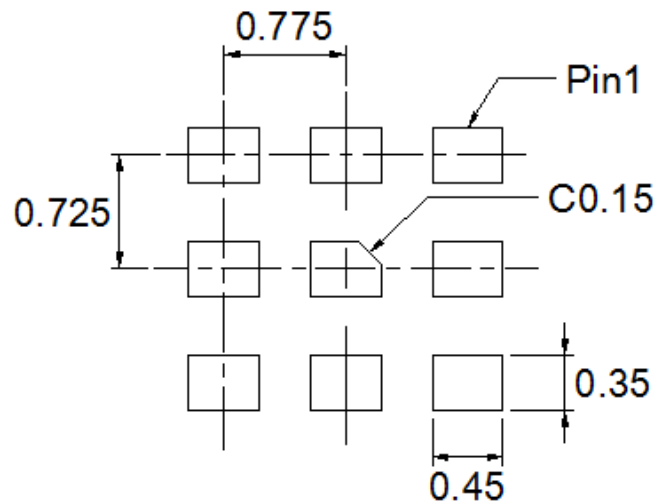

RECOMMENDED LAND PATTERN

RECOMMENDED STENCIL PATTERN
BASED ON 130µm THICKNESS STENCIL

PACKING REFERENCE:

Unit: mm

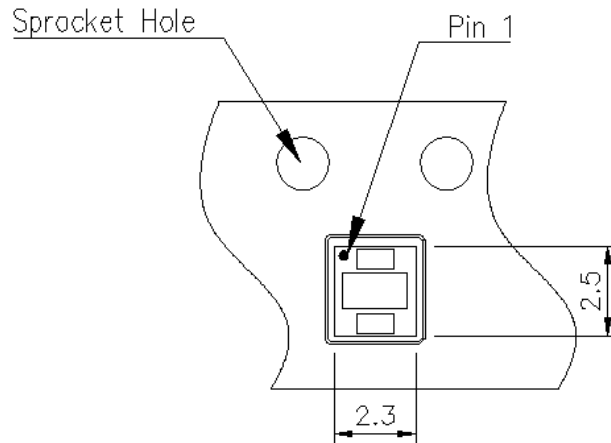
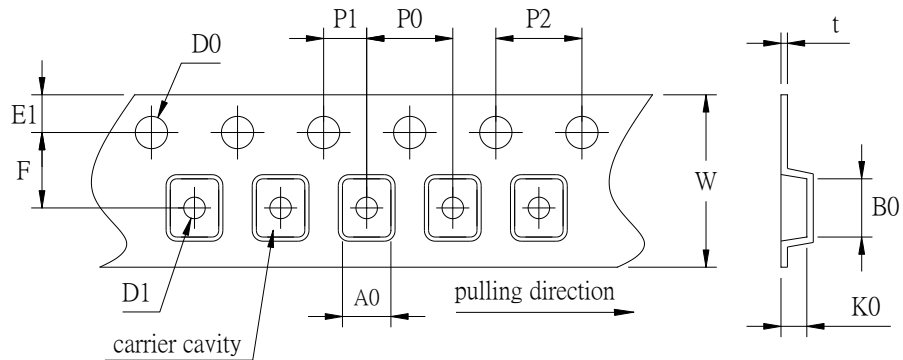
Package In Tape Loading Orientation

Tape Dimension

A0	2.65 ± 0.10	E1	1.75 ± 0.10
B0	2.90 ± 0.10	K0	1.25 ± 0.10
F	3.50 ± 0.05	P0	4.00 ± 0.10
W	$8.00 +0.30/-0.10$	P1	2.00 ± 0.05
D0	$\varphi 1.50 +0.1/-0.0$	P2	4.00 ± 0.10
D1	$\varphi 1.0 +0.1/-0.0$	t	0.25 ± 0.05

PACKING REFERENCE: (Cont.)

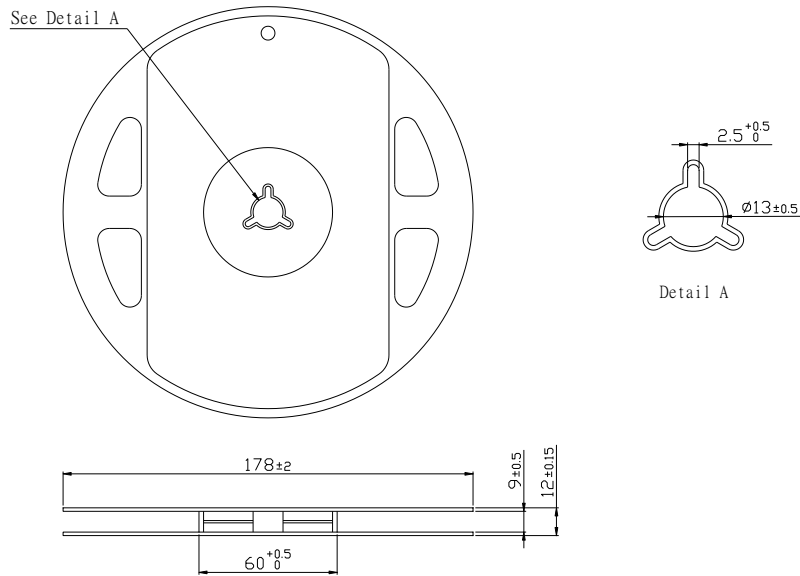
Unit: mm

Reel Dimension

Peel Strength of Top Cover Tape

The peel speed shall be about 300mm/min.

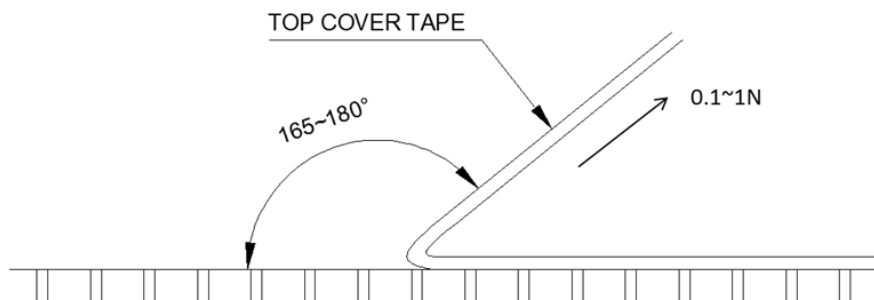
The peel force of top cover tape shall be between 0.1N to 1.0N



REVERSION HISTORY:

Date	Revision	Changes
2015.09.01	01	Release of the preliminary specification.
2015.11.13	02	Change recommendation reflow profile